

Instruction Manual



P/N 30-3519 1993-1998 Toyota Supra MKIV Twin Turbo 2JZ-GTE AEM Infinity PnP Harness



STOP!

THIS PRODUCT HAS LEGAL RESTRICTIONS.
READ THIS BEFORE INSTALLING/USING!

THIS PRODUCT MAY BE USED SOLELY ON VEHICLES USED IN SANCTIONED COMPETITION WHICH MAY NEVER BE USED UPON A PUBLIC ROAD OR HIGHWAY, UNLESS PERMITTED BY SPECIFIC REGULATORY EXEMPTION. (VISIT THE "EMISSIONS" PAGE AT [HTTP://WWW.SEMASAN.COM/EMISSIONS](http://www.semasan.com/emissions) FOR STATE BY STATE DETAILS.)

IT IS THE RESPONSIBILITY OF THE INSTALLER AND/OR USER OF THIS PRODUCT TO ENSURE THAT IT IS USED IN COMPLIANCE WITH ALL APPLICABLE LAWS AND REGULATIONS. IF THIS PRODUCT WAS PURCHASED IN ERROR, DO NOT INSTALL AND/OR USE IT. THE PURCHASER MUST ARRANGE TO RETURN THE PRODUCT FOR A FULL REFUND.

THIS POLICY ONLY APPLIES TO INSTALLERS AND/OR USERS WHO ARE LOCATED IN THE UNITED STATES; HOWEVER CUSTOMERS WHO RESIDE IN OTHER COUNTRIES SHOULD ACT IN ACCORDANCE WITH THEIR LOCAL LAWS AND REGULATIONS.

WARNING: This installation is not for the tuning novice! Use this system with **EXTREME** caution! The AEM Infinity Programmable EMS allows for total flexibility in engine tuning. Misuse or improper tuning of this product can destroy your engine! If you are not well versed in engine dynamics and the tuning of engine management systems **DO NOT** attempt the installation. Refer the installation to an AEM-trained tuning shop or call 800-423-0046 for technical assistance.

NOTE: All supplied AEM calibrations, Wizards and other tuning information are offered as potential starting points only. **IT IS THE RESPONSIBILITY OF THE ENGINE TUNER TO ULTIMATELY CONFIRM IF THE CALIBRATION IS SAFE FOR ITS INTENDED USE.** AEM holds no responsibility for any engine damage that results from the misuse or mistuning of this product!

AEM Performance Electronics
AEM Performance Electronics, 2205 126th Street Unit A, Hawthorne, CA 90250
Phone: (310) 484-2322 Fax: (310) 484-0152
<http://www.aemelectronics.com>
Instruction Part Number: 10-3519
Document Build 9/15/2017

OVERVIEW

The 30-3519 AEM Infinity Adapter Kit is designed for the 1993–1998 Toyota Supra MKIV Twin Turbo (manual transmission). This is a true standalone system that eliminates the use of the factory ECU. The use of this adapter makes the kit “plug and play” so no cutting or splicing wires is necessary. The base configuration files available for the Infinity EMS are starting points only and will need to be modified for every specific application.

The available Infinity EMS part numbers for this adapter kit are:

- 30-7106 INFINITY 506
- 30-7108 INFINITY 508

Please read this document in its entirety before attempting to start or run an engine.

GETTING STARTED

Your Infinity EMS will be packaged with four important documents: Usage Legality Disclaimer, Software Download Notice, Security Code Notice, and an Infinity Quick Start Guide.

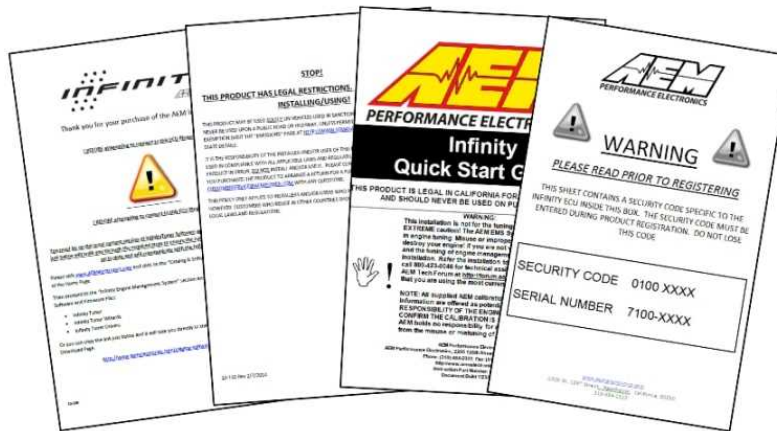

First, read and acknowledge the Usage Legality Disclaimer. Second, refer to the Infinity Quick Start Guide (QSG). Third, follow the Software Download Notice and download the Infinity Tuner software from the AEM Electronics web site (section 2.1 in QSG). Fourth, visit www.aeminfinity.com to register your EMS (section 3.2 in QSG). Once the registration process is complete, you'll be able to download the latest firmware for your Infinity. The final setup process is to open the Infinity Tuner software and connect to your Infinity to update the firmware (section 3.3 in QSG). This can be done once the Infinity is installed into your vehicle - see Installation section.

Once the Infinity is installed into your vehicle and it has been loaded with the latest firmware, setup and tuning may commence. Refer to the QSG for additional information on getting the engine ready for tuning with the Infinity EMS. Additionally, the full Infinity User Manual can be referenced for more in-depth information pertaining to the install, setup, and usage of the Infinity EMS.

IMPORTANT APPLICATION NOTES

The 30-3519 AEM Infinity PnP Harness allows for a "plug and play" installation of either an AEM Infinity 506 or 508 EMS into a 1993–1998 Toyota Supra MKIV Twin Turbo 2JZ-GTE (manual transmission only). This kit completely replaces the stock ECU and offers full control of fuel injection, ignition timing advance, and all other engine control functions.

Sensors and Speed Density Fueling

The Infinity will run the engine with speed density fueling control using the stock Supra Manifold Air Pressure (MAP), Intake Air Temperature (IAT) and Coolant Temperature (CLT) sensors. The factory Mass Air Flow (MAF) sensor is not supported and can be removed, however, the IAT sensor is integral with the MAF sensor and if the MAF is removed, a separate IAT sensor must be wired in. The stock Supra MAP sensor reads up to 230kpa. The stock MAP sensor can be replaced by a higher reading aftermarket sensor but should be connected to the Infinity using the factory MAP sensor wiring.

Stepper Idle Control Modifications

The stock Supra stepper idle control motor is a unipolar type and **MUST** be modified to work with the Infinity's bipolar stepper motor control. Modification process is covered in Installation section.

Fuel Pump Control

The stock Supra fuel pump controller is supported by the Infinity, however it is not configurable to vary pump speed to control fuel pressure/flow. The fuel pump controller is ran at high output at all times. ***WARNING*** The fuel pump controller signal from the Infinity is a 5v signal and can not be used to trigger a fuel pump relay directly. Lowside 0 is available in the Aux Connector and should be used to trigger any add on fuel pump relays - see pin out.

Fuel Injectors and Injector Resistor Pack

The stock Supra injectors are low impedance, but because the stock ECU does not have peak and hold capabilities, there is a resistor pack (shown below) to prevent excessive current to the stock ECU's saturated injector drivers.

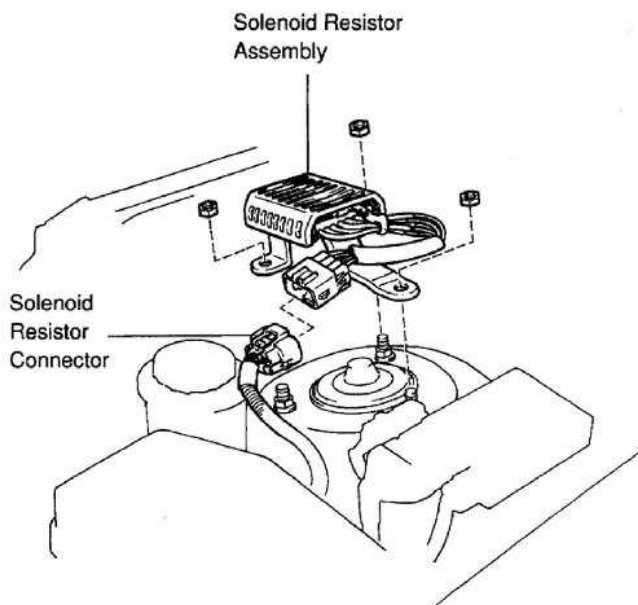

If an Infinity 506 is installed, users have the option to remove and bypass the OEM resistor pack for direct control of low impedance, peak and hold injectors. If the resistor pack is removed, low impedance injectors should be setup as peak and hold type in the Setup Wizard. Note that resistor pack removal is not mandatory when using the stock or other low impedance injectors however, if high impedance, saturated injectors are to be used, the resistor pack must be removed otherwise the injectors will not receive enough current to operate correctly. To remove the resistor pack, unplug the connector and jump the main 12v input wire directly to all six injector wires (see below). With the resistor pack and low impedance injectors in place, the injectors should be setup as regular saturated injectors in the wizard.

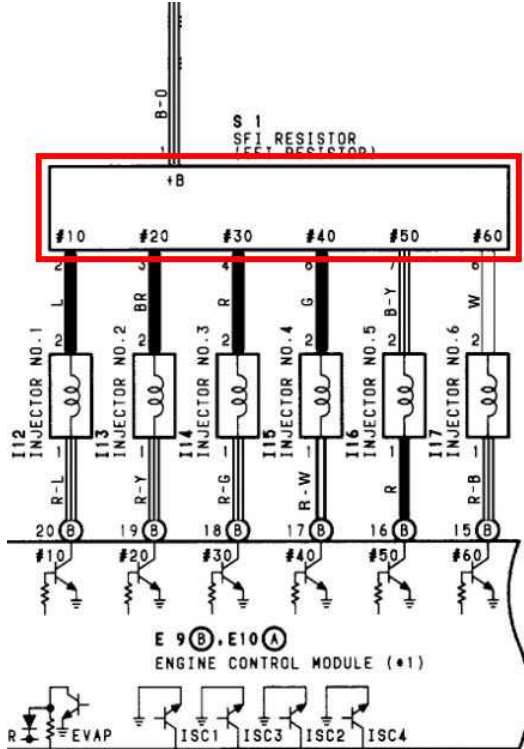

If an Infinity 508 is installed, the resistor pack must be retained if the stock or other low impedance, peak and hold injectors are used. **The Infinity 508 does NOT support peak and hold injectors directly and there must be a net resistance >10 ohms on each injector circuit.** Hardware damage due to usage with peak and hold injectors is NOT covered under warranty. The resistor pack must be removed if high impedance, saturated injectors are used otherwise the injectors will not receive enough current to operate correctly. High impedance injectors and low impedance injectors used with the resistor pack in place should be setup as saturated injectors in the wizard.

Unsupported Vehicle Features

The following stock functions are not supported with the Infinity: automatic transmission control, TRAC traction control, MAF sensor, and sequential turbo control.

UEGO Wideband Oxygen Sensor

The Infinity includes on board control for one UEGO wideband oxygen sensor. A Bosch LSU 4.2 oxygen sensor (available separately) can be directly connected to the adapter harness via an O2 Sensor Extension Harness. An oxygen sensor bung (available separately) should be welded into the exhaust system after the turbo(s) but before the catalytic converter (if still equipped).

30-2001	Bosch LSU 4.2 Wideband UEGO Replacement Sensor
30-3600	Infinity O2 Sensor Extension Harness
35-4005	O2 Sensor Bung, Mild Steel
35-4008	O2 Sensor Bung, Tall Stainless Steel

KIT CONTENTS

Item	AEM P/N	Description	Qty
A	36-3519	Supra PnP Adapter Harness	1
B	4-2021	Deutsch DTM Socket Terminals	12
C	4-1020/4-4013	Deutsch DTM Plug, 12 Position w/Wedgelock	1
D	10-3519	Instruction Sheet, 30-3519	1

INFINITY CONNECTORS

The AEM Infinity EMS uses the MX123 Sealed Connection System from Molex. AEM strongly recommends that users become familiar with the proper tools and procedures before attempting any modifications. The entire user manual can be downloaded direct from Molex at:

http://www.molex.com/mx_upload/family/MX123UserManual.pdf



INFINITY ADAPTER HARNESS

The AEM Infinity Plug and Play Harness connects between the stock Toyota harness and the AEM Infinity ECU, completely replacing the stock ECU. The harness connections for the various sensors and auxiliary options are described here.



Connections

Lambda - This 6-way DTM-style connector plugs directly into an optional AEM UEGO extension harness, **AEM P/N 30-3600**. The Bosch LSU 4.2 UEGO Sensor, **AEM P/N 30-2001**, will plug into that extension harness. Refer to 'UEGO Sensor' section for mounting requirements.

AUX - This 12-way connector is used to adapt many common ancillary inputs and outputs easily. Included in this kit are a 12-way mating connector, 12 terminals, and a connector wedgelock. These components will need to be terminated by the installer with 16-22ga wire. Note: the pin numbering is molded on the wire side of the connector. See Pinouts section for details of this connector's pins.

Flash - This 2-way connector is used for secondary hardware flashing. This connector is normally protected with a dust cap. The included shunt connector jumps the two wires together when required. Once initially flashed, the EMS is normally upgraded in the software, not requiring this connector.

AEMnet - This 4-way connector is for AEMnet, an open architecture based on CAN 2.0 which provides the ability for multiple enabled devices, such as dashboards, data loggers, etc. to easily communicate with one another through two twisted cables (CAN+/CAN-). Support for data transmit to an AEM AQ-1 Datalogger and data receive from one or more AEM 4-Channel Wideband UEGO Controllers are supported.



INSTALLATION

1. Disconnect battery negative cable. Remove door sill scuff plate and pull back carpet to gain access to stock ECU.

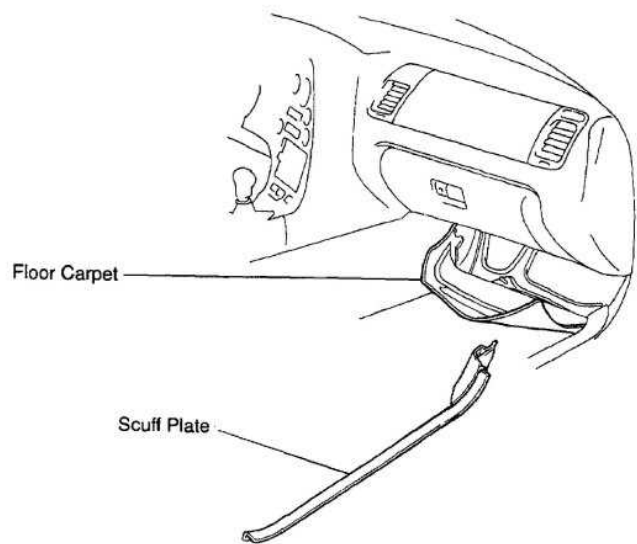

2. Remove ECU protector cover. Unbolt ECU from mount. Disconnect wiring harness from ECU: press down on A connector latch and remove; gently rock connector B while loosening bolt in center of connector housing until removed.

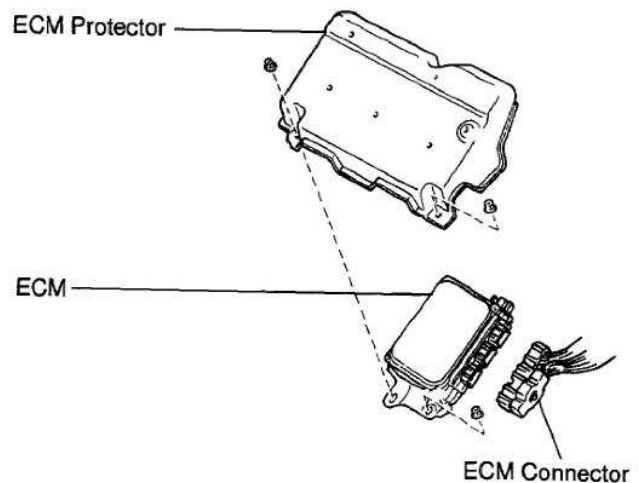

3. Attach the stock wiring harness to the Infinity PnP adapter harness: plug in A connector until fully seated and latched; gently tighten bolt to draw B connector into harness ensuring connector stays straight. Verify the connector is fully seated and snug the bolt. **DO NOT FORCE CONNECTOR AND DO NOT OVER TIGHTEN BOLT.**



4. Locate the idle air control (IAC) motor on the engine. Disconnect the connector from the IAC.

The two center pins (black/red wires) supply 12v to the stepper motor in the stock setup however these pins **MUST BE DISCONNECTED** when using the Infinity.



5. Using a small flat-blade screwdriver or pick, carefully remove the terminal lock.



6. Carefully lift the terminal locks while pulling the wires out from the backside of the connector to remove the two center pins.



7. Insulate both wires with heat shrink and secure to nearby harness loom.

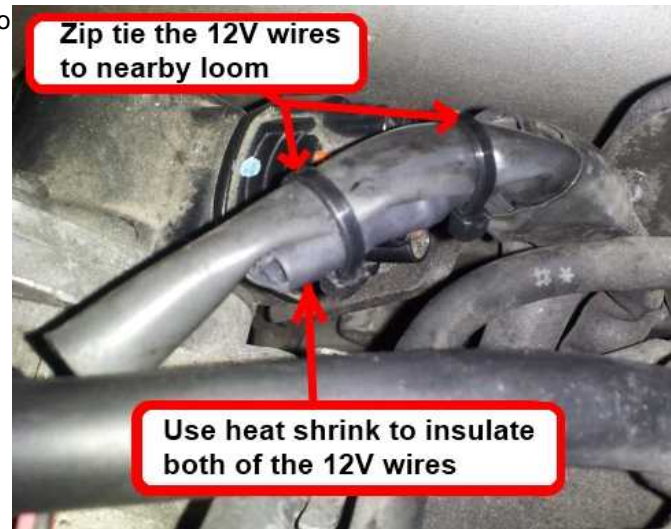

8. Plug in additional connectors to adapter harness as necessary. Additional inputs such as Flex Fuel, fuel pressure, oil pressure, oil temp, etc, will be inputted through Aux connector. Connect 6 pin LAMBDA connector to 30-2001 Bosch LSU 4.2 UEGO sensor using 30-3600 O2 Sensor Extension Harness (both items sold separately). Plug in 80 pin connector to Infinity. Swing the latch over to draw the connector down into position. The latch will click in position. Slide the the red lock into place to secure the latch. Reconnect battery negative cable. Installation complete.



PINOUTS

Infinity Pin	Hardware Reference	Supra Function	Supra Pin Destination	Hardware Specification	Notes
C1-1	Lowside 4	A/C Compressor	23A	Lowside switch, 1.7A max, NO internal flyback diode. 12v pullup.	Configured in Supra base session for A/C compressor activation.
C1-2	Lowside 5	Tachometer	16A/38A	Lowside switch, 6A max with internal flyback diode. Inductive load should NOT have full time power. 12v pullup.	Configured in Supra base session for tachometer.
C1-3	Lowside 6 (Inf 506 Only)	Not used	No connect	Lowside switch, 6A max with internal flyback diode. Inductive load should NOT have full time power. No pullup.	Not used.
C1-3	Injector 7 (Inf 508 Only)	Not used	No connect	For use with high impedance (10-15ohms) injectors only, 1.7A max.	Not used.
C1-4	Lowside 7 (Inf 506 Only)	Not used	No connect	Lowside switch, 6A max, NO internal flyback diode. No pullup.	Not used.
C1-4	Injector 8 (Inf 508 Only)	Not used	No connect	For use with high impedance (10-15ohms) injectors only, 1.7A max.	Not used.
C1-5	UEGO 1 Heat	UEGO Heat	Lambda 4	Bosch UEGO controller	Internal UEGO controller. Use 30-3600 Wideband O2 Extension Harness and 30-2001 Bosch LSU 4.2 Wideband UEGO Sensor.
C1-6	UEGO 1 IA	UEGO IA	Lambda 2		
C1-7	UEGO 1 IP	UEGO IP	Lambda 6		
C1-8	UEGO 1 UN	UEGO UN	Lambda 1		
C1-9	UEGO 1 VM	UEGO VM	Lambda 5		
C1-10	Batt Perm Power	Permanent Power	33A	Dedicated power management CPU	Full time battery power. MUST be powered before the ignition switch input is triggered (See C1-48).
C1-11	Coil 4	Coil 4	54B	25 mA max source current	Triggers coil through factory ignitor with 5v falling edge trigger. DO NOT connect directly to coil primary!
C1-12	Coil 3	Coil 3	55B	25 mA max source current	Triggers coil through factory ignitor with 5v falling edge trigger. DO NOT connect directly to coil primary!
C1-13	Coil 2	Coil 2	56B	25 mA max source current	Triggers coil through factory ignitor with 5v falling edge trigger. DO NOT connect directly to coil primary!
C1-14	Coil 1	Coil 1	57B	25 mA max source current	Triggers coil through factory ignitor with 5v falling edge trigger. DO NOT connect directly to coil primary!
C1-15	Coil 6	Coil 6	52B	25 mA max source current	Triggers coil through factory ignitor with 5v falling edge trigger. DO NOT connect directly to coil primary!
C1-16	Coil 5	Coil 5	53B	25 mA max source current	Triggers coil through factory ignitor with 5v falling edge trigger. DO NOT connect directly to coil primary!
C1-17	Crank Position Sensor VR+	Crank Position Sensor VR+	27B	Differential Variable Reluctance Zero Cross Detection	VR crank input.
C1-18	Crank Position Sensor VR-	Crank Position Sensor VR-	7B		
C1-19	Cam Position Sensor 1 VR-	Cam Position Sensor 1 VR-	6B	Differential Variable Reluctance Zero Cross Detection	VR cam input.
C1-20	Cam Position Sensor 1 VR+	Cam Position Sensor 1 VR+	26B		
C1-21	Lowside 2	Available Output	Aux 10	Lowside switch, 1.7A max, NO internal flyback diode. No pullup.	Available lowside output. See Output Function Assignment in Setup Wizard.
C1-22	Lowside 3	MIL	6A	Lowside switch, 6A max with internal flyback diode. Inductive load should NOT have full time power. No pullup.	Configured in Supra base session as Malfunction Indicator Lamp. See Output Function Assignment in Setup Wizard.
C1-23	AGND	Sensor Ground	65B	Dedicated analog ground	Sensor ground for 0-5v analog inputs.
C1-24	AGND	Sensor Ground	Aux 3	Dedicated analog ground	Sensor ground for 0-5v analog inputs.
C1-25	Crank Position Sensor 1 Hall	Not used	No connect	10K pullup to 12V. Will work with ground or floating switches. Frequency input only.	Not used.
C1-26	Cam Position Sensor 1 Hall	Not used	No connect	10K pullup to 12V. Will work with ground or floating switches. Frequency input only.	Not used.
C1-27	Digital 2	Not used	No connect	10K pullup to 12V. Will work with ground or floating switches. Frequency input only.	Not used.
C1-28	Digital 3	Available Frequency Input	Aux 6	10K pullup to 12V. Will work with ground or floating switches. Frequency input only.	Can be used for Flex Fuel or Turbo Speed or other frequency input. See Setup Wizard to configure input.
C1-29	Digital 4	Vehicle Speed	2A	10K pullup to 12V. Will work with ground or floating switches. Frequency input only.	VSS input.

C1-30	Digital 5	Available Switch Input	Aux 9	10K pullup to 12V. Will work with ground or floating switches. Switch input only.	Can be used as switch input for Brake Switch, Clutch Switch, Rolling Launch Switch, etc. See Input Function Assignments>Switches in Setup Wizard.
C1-31	Digital 6	Not used	No connect	10K pullup to 12V. Will work with ground or floating switches. Frequency input only.	Not used.
C1-31	Coil 7 (Inf 508 Only)	Not used	No connect	25 mA max source current	Not used.
C1-32	Digital 7	Not used	No connect	10K pullup to 12V. Will work with ground or floating switches. Switch input only.	Not used.
C1-32	Coil 8 (Inf 508 Only)	Not used	No connect	25 mA max source current	Not used.
C1-33	Power Ground	Ground	4B	Power ground	Power ground.
C1-34	CAN A-	AEMnet CAN-	AEMnet	Dedicated high speed CAN transceiver	Four pin DTM connector in AEM adapter harness. Connect with AEMnet enabled devices.
C1-35	CAN A+	AEMnet CAN+	AEMnet	Dedicated high speed CAN transceiver	Four pin DTM connector in AEM adapter harness. Connect with AEMnet enabled devices.
C1-36	CAN B-	Not used	No connect	Dedicated high speed CAN transceiver	Not used.
C1-37	CAN B+	Not used	No connect	Dedicated high speed CAN transceiver	Not used.
C1-38	Temp 1	Coolant Temp Sensor	44B	2.49k pullup to 5v	Supra coolant temp sensor.
C1-39	Temp 2	Air Temp Sensor	45B	2.49k pullup to 5v	Supra air temp sensor in MAF housing. If MAF is removed, separate temp sensor must be wired in.
C1-40	Temp 3	Spare Temp Input	Aux 2	2.49k pullup to 5v	Can be used for Oil Temperature input. See Setup Wizard Oil Temperature page.
C1-41	Lowside 0	Fuel Pump Relay	Aux 7	Lowside switch, 4A max, NO internal flyback diode. No pullup.	Can be used to trigger a separate fuel pump relay if factory fuel pump ECU is not used. See Output Function Assignments in Setup Wizard for additional options.
C1-42	Lowside 1	Boost Control	60B	Lowside switch, 4A max with internal flyback diode. Inductive load should NOT have full time power. No pullup.	Configured in Supra base session for boost control. See Setup Wizard Boost Control page for options. Monitor BoostControl [%] channel for output state.
C1-43	Power Ground	Ground	80B	Power ground	Power ground.
C1-44	Knock Sensor 1	Knock Sensor 1	50B	Dedicated knock signal processor	Knock sensor input for cylinders 1-3.
C1-45	Knock Sensor 2	Knock Sensor 2	49B	Dedicated knock signal processor	Knock sensor input for cylinders 4-6.
C1-46	Power Ground	Ground	69B	Power ground	Power ground.
C1-47	Main Relay Control	Ground out to main relay	Main Relay	0.7A max ground sink for external relay control	Triggers main relay in adapter harness which in turn triggers the car's main relay.
C1-48	Ign Switch	Ignition Switch	1A	10k pulldown	Full time battery power must be available at C1-10 before this input is triggered.
C1-49	+5V	+5V Sensor Power	41B	Regulated, fused +5V supply for sensor power	Analog sensor power.
C1-50	+5V	+5V Sensor Power	Aux 4	Regulated, fused +5V supply for sensor power	Analog sensor power.
C1-51	Analog 7	TPS	43B	12 bit A/D, 100K pullup to 5V	TPS input. See Throttle Range Setup Wizard.
C1-52	Analog 8	MAP Sensor	62B	12 bit A/D, 100K pullup to 5V	MAP input. See Basic Sensors.
C1-53	Analog 9	Fuel Pressure	Aux 1	12 bit A/D, 100K pullup to 5V	Can be used as a Fuel Pressure input for fuel delivery calculation. See the Setup Wizard Fuel Pressure page for setup and calibration. Monitor FuelPressure [psig] channel.
C1-54	VR+_In_2	Not used	No connect	Differential Variable Reluctance Zero	Not used.
C1-55	VR-_In_2	Not used	No connect	Cross Detection	Not used.
C1-56	VR-_In_3	Not used	No connect	Differential Variable Reluctance Zero	Not used.
C1-57	VR+_In_3	Not used	No connect	Cross Detection	Not used.
C1-58	Highside 0	Fuel Pump ECU	22A	2.6A max, High Side Solid State Relay	Provides 5v through resistor arrangement to trigger stock fuel pump ECU.
C1-59	Stepper 1B	Stepper Idle 1B	35B	Automotive, Programmable Stepper Driver, up to 28V and $\pm 1.4A$	Stepper idle. Center pins that provide 12v to stepper idle motor must be removed.
C1-60	Stepper 2B	Stepper Idle 2B	32B	Automotive, Programmable Stepper Driver, up to 28V and $\pm 1.4A$	Stepper idle. Center pins that provide 12v to stepper idle motor must be removed.
C1-61	DBW1 Motor-	Not used	No connect	5.0A max Throttle Control Hbridge Drive	Not used.
C1-62	DBW1 Motor+	Not used	No connect	5.0A max Throttle Control Hbridge Drive	Not used.
C1-63	+12v	+12v	31A	12v power from main relay	12v power from main relay.
C1-64	Injector 6	Injector 6	15B	Peak and hold, 3A max for Inf 506. Saturated injector driver for Inf 508.	Injector 6.
C1-65	Injector 5	Injector 5	16B	Peak and hold, 3A max for Inf 506. Saturated injector driver for Inf 508.	Injector 5.

C1-66	Injector 4	Injector 4	17B	Peak and hold, 3A max for Inf 506. Saturated injector driver for Inf 508.	Injector 4.
C1-67	Power Ground	Ground	78B/79B	Power ground	Power ground.
C1-68	+12v	Not used	32A	12v power from main relay	Not used.
C1-69	Analog 19	Not used	No connect	12 bit A/D, 100K pullup to 5V	Not used.
C1-70	Analog 18	Not used	No connect	12 bit A/D, 100K pullup to 5V	Not used.
C1-71	Analog 16	A/C Request Switch	34A	12 bit A/D, 100K pullup to 5V	A/C request switch input.
C1-72	Flash Enable	Flash Enable	Flash Enable Connector	10k pulldown	Two pin DTM connector in AEM adapter harness. Use only to force EMS into flash mode if normal firmware update procedure does not work.
C1-73	Analog 13	Spare Analog Input	Aux 5	12 bit A/D, 100K pullup to 5V	Can be used as Oil Pressure, Mode Switch, 3-Step or other analog input. See Oil Pressure or Input Function Assignments in Setup Wizard.
C1-74	Analog 11	Spare Analog Input	Aux 12	12 bit A/D, 100K pullup to 5V	Can be used as ShiftSwitch, Mode Switch, 3-Step or other analog input. See Shift Cut or Input Function Assignments in Setup Wizard.
C1-75	Analog 10	Spare Analog Input	Aux 11	12 bit A/D, 100K pullup to 5V	Can be used as Barometric Pressure, Mode Switch, 3-Step or other analog input. See Barometric Pressure or Input Function Assignments in Setup Wizard.
C1-76	Injector 3	Injector 3	18B	Peak and hold, 3A max for Inf 506. Saturated injector driver for Inf 508.	Injector 3.
C1-77	Injector 2	Injector 2	19B	Peak and hold, 3A max for Inf 506. Saturated injector driver for Inf 508.	Injector 2.
C1-78	Injector 1	Injector 1	20B	Peak and hold, 3A max for Inf 506. Saturated injector driver for Inf 508.	Injector 1.
C1-79	Stepper 2A	Stepper 2A	34B	Automotive, Programmable Stepper Driver, up to 28V and ±1.4A	Stepper idle. Center pins that provide 12v to stepper idle motor must be removed.
C1-80	Stepper 1A	Stepper 1A	33B	Automotive, Programmable Stepper Driver, up to 28V and ±1.4A	Stepper idle. Center pins that provide 12v to stepper idle motor must be removed.

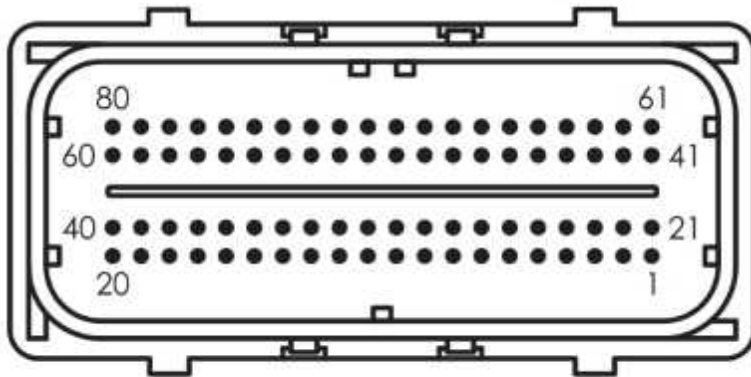

INFINITY "C1" 80 PIN

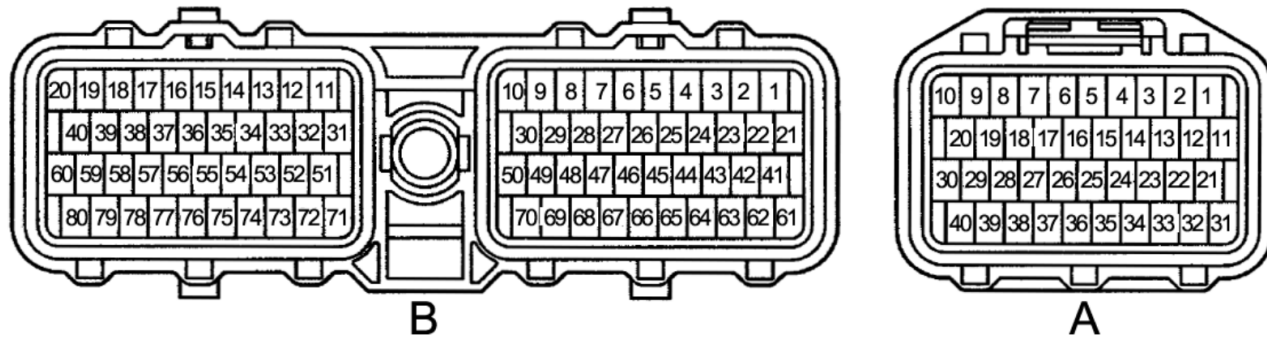

Toyota Pin Numbering - Wire Entry View

AUX		
Pin	Dest. Pin	Default Pin Function
1	C1-53	Analog 9 (Fuel Press)
2	C1-40	Temp 3 (Oil Temp)
3	C1-24	Sensor Ground
4	C1-50	+5V
5	C1-73	Analog 13 (Oil Press)
6	C1-28	Digital 3 (Freq Input)
7	C1-41	Lowside 0 (Fuel Pump)
8	C1-68	+12V
9	C1-30	Digital 5 (Switch Input)
10	C1-21	Lowside 2 (Available)
11	C1-75	Analog 10 (Baro)
12	C1-74	Analog11 (Available)

LAMBDA		
Pin	Dest. Pin	Default Pin Function
1	C1-8	UEGO Control
2	C1-6	
3	C1-68	+12V
4	C1-5	UEGO Control
5	C1-9	
6	C1-7	

AEMnet		
Pin	Dest. Pin	Default Pin Function
1	C1-35	AEMnet +
2	C1-34	AEMnet -
3	C1-68	+12V
4	C1-67	Ground

FLASH		
Pin	Dest. Pin	Default Pin Function
A	C1-10	+12V Perm Power
B	C1-72	Flash Enable

12 MONTH LIMITED WARRANTY

Advanced Engine Management Inc. warrants to the consumer that all AEM High Performance products will be free from defects in material and workmanship for a period of twelve (12) months from date of the original purchase. Products that fail within this 12-month warranty period will be repaired or replaced at AEM's option, when determined by AEM that the product failed due to defects in material or workmanship. This warranty is limited to the repair or replacement of the AEM part. In no event shall this warranty exceed the original purchase price of the AEM part nor shall AEM be responsible for special, incidental or consequential damages or cost incurred due to the failure of this product. Warranty claims to AEM must be transportation prepaid and accompanied with dated proof of purchase. This warranty applies only to the original purchaser of product and is non-transferable. All implied warranties shall be limited in duration to the said 12-month warranty period. Improper use or installation, accident, abuse, unauthorized repairs or alterations voids this warranty. AEM disclaims any liability for consequential damages due to breach of any written or implied warranty on all products manufactured by AEM. Warranty returns will only be accepted by AEM when accompanied by a valid Return Merchandise Authorization (RMA) number. Product must be received by AEM within 30 days of the date the RMA is issued.

UEGO oxygen sensors are considered wear items and are not covered under warranty.

Please note that before AEM can issue an RMA for any electronic product, it is first necessary for the installer or end user to contact the EMS tech line at 1-800-423-0046 to discuss the problem. Most issues can be resolved over the phone. Under no circumstances should a system be returned or a RMA requested before the above process transpires.

AEM will not be responsible for electronic products that are installed incorrectly, installed in a non-approved application, misused, or tampered with.

Any AEM electronics product can be returned for repair if it is out of the warranty period. There is a minimum charge of \$50.00 for inspection and diagnosis of AEM electronic parts. Parts used in the repair of AEM electronic components will be extra. AEM will provide an estimate of repairs and receive written or electronic authorization before repairs are made to the product.